

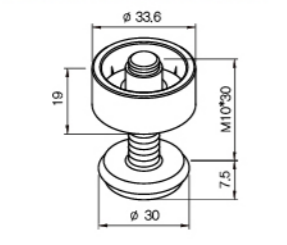









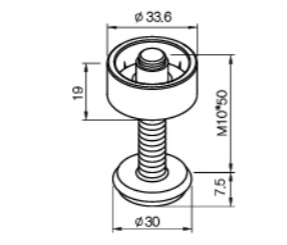

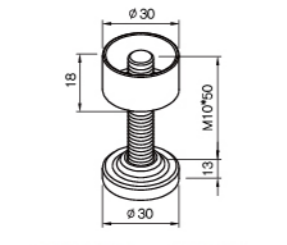
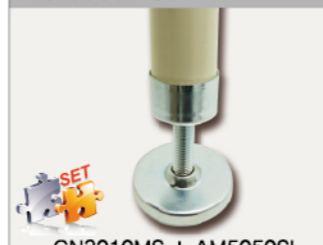
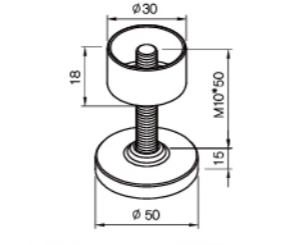

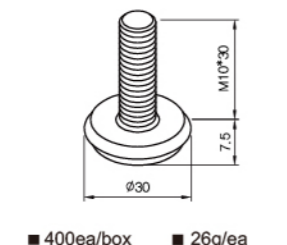

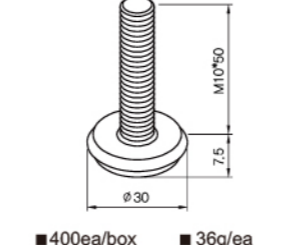

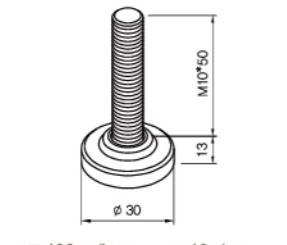

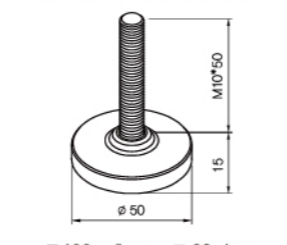

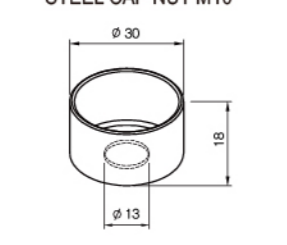

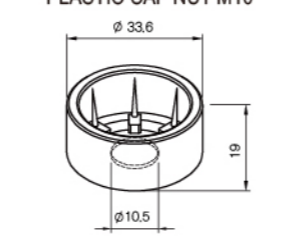
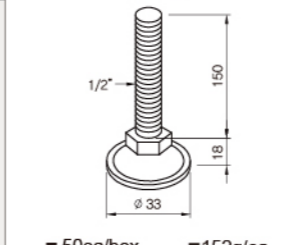
ADJUSTERS

<p>AS-3030MP</p>  <p>CN3010MP + AM3030PS</p>	<p>P/ADJUSTER M10 SMALL SET</p>  <p>■ 100ea/box ■ 40g/ea</p>	<p>AS-3050MP</p>  <p>CN3010MP + AM3050PL</p>	<p>P/ADJUSTER M10 LARGE SET</p>  <p>■ 100ea/box ■ 50g/ea</p>
<p>AS-3050MS</p>  <p>CN3010MS + AM3050SS</p>	<p>ADJUSTER M10 SMALL SET</p>  <p>■ 150ea/box ■ 64g/ea</p>	<p>AS-5050MS</p>  <p>CN3010MS + AM5050SL</p>	<p>ADJUSTER M10 LARGE SET</p>  <p>■ 100ea/box ■ 92g/ea</p>
<p>AM-3030PS</p> 	<p>P/ADJUSTER M10 SMALL</p>  <p>■ 400ea/box ■ 26g/ea</p>	<p>AM-3050PL</p> 	<p>P/ADJUSTER M10 LARGE</p>  <p>■ 400ea/box ■ 36g/ea</p>
<p>AM-3050SS</p> 	<p>ADJUSTER M10 SMALL</p>  <p>■ 400ea/box ■ 40g/ea</p>	<p>AM-5050SL</p> 	<p>ADJUSTER M10 LARGE</p>  <p>■ 400ea/box ■ 68g/ea</p>
<p>CN-3010MS</p> 	<p>STEEL CAP NUT M10</p>  <p>■ 400ea/box ■ 24g/ea</p>	<p>CN-3010MP</p> 	<p>PLASTIC CAP NUT M10</p>  <p>■ 300ea/box ■ 14g/ea</p>

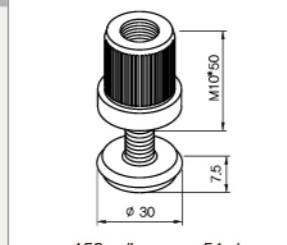
ADJUSTERS

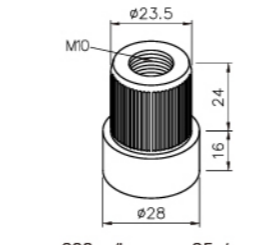
<p>AD-3012SS (OLD:AD-3012S)</p> 	<p>ADJUSTER(1/2") 30*50L</p>  <p>■ 150ea/box ■ 76g/ea</p>	<p>AD-5012LS (OLD:AD-5012L)</p> 	<p>ADJUSTER(1/2") 50*50L</p>  <p>■ 150ea/box ■ 94g/ea</p>
<p>AD-3012SL</p> 	<p>ADJUSTER(1/2") 30*100L</p>  <p>■ 100ea/box ■ 115g/ea</p>	<p>AD-5012LL</p> 	<p>ADJUSTER(1/2") 50*100L</p>  <p>■ 80ea/box ■ 132g/ea</p>
<p>AD-3012SX (OLD:AD-3012XL)</p> 	<p>ADJUSTER(1/2") 30*150L</p>  <p>■ 50ea/box ■ 152g/ea</p>	<p>AD-5012LX (OLD:AD-5012XL)</p> 	<p>ADJUSTER(1/2") 50*150L</p>  <p>■ 50ea/box ■ 172g/ea</p>
<p>AC-3828RB</p> 	<p>ADJUSTER RUBBER CAP</p>  <p>■ 400ea/box ■ 8g/ea</p>	<p>AC-3829RB</p> 	<p>RUBBER FOOT CAP</p>  <p>■ 500ea/box ■ 26g/ea</p>
<p>TL-4000</p> 	<p>SPANNER</p>  <p>■ 50ea/box ■ 130g/ea</p>		

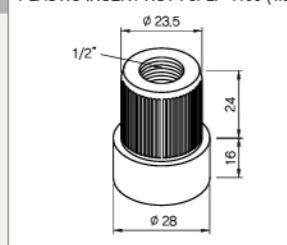
INSERT NUTS - PLASTIC

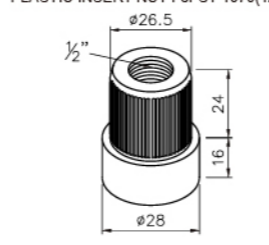
<p>AS-3040MP</p>  <p>IN-1010LP + AM-3050PL (INSERTED M10 STEEL BOLT)</p>	<p>PLASTIC ADJUSTER M10 SET</p>  <p>■ 150ea/box ■ 51g/ea</p>	<p>IN-1010LP</p>  <p>(INSERTED 10MM STEEL BOLT)</p>	<p>PLASTIC INSERT NUT For LP-1100 (M10)</p>  <p>■ 200ea/box ■ 25g/ea</p>
<p>IN-1210LP</p>  <p>(INSERTED 1/2" STEEL BOLT)</p>	<p>PLASTIC INSERT NUT For LP-1100 (1/2")</p>  <p>■ 200ea/box ■ 15g/ea</p>	<p>IN-1207SP ⚡ 도전성</p>  <p>(INSERTED 1/2" STEEL BOLT)</p>	<p>PLASTIC INSERT NUT For ST-1070(1/2")</p>  <p>■ 200ea/box ■ 15g/ea</p>

INSERT NUTS - STEEL

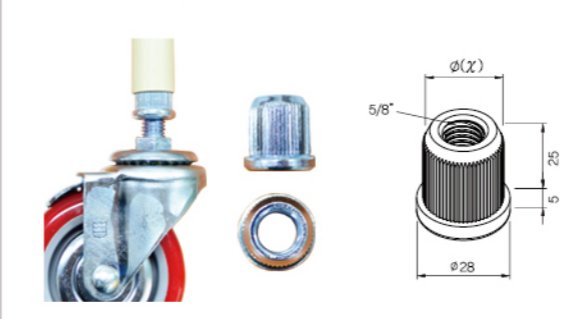

INSERT NUT (1/2")		PRODUCT CODE	Q'ty / BOX	UNIT WEIGHT	φ(χ)	THICKNESS (PIPE두께)	PIPES	MODEL
 <p>For Adjuster / Bolt Caster 2"</p>	IN-1210L	300	88g	23.6	t1.0	FOR LOGIFORM PIPE	LP-1100	
	IN-1220L		60g	21.6	t2.0		LP-1200	
	IN-1207S		95g	26.4	t0.7	FOR STAINLESS PIPE	ST-1070	
	IN-1211S		85g	25.6	t1.1		ST-1110	

INSERT NUT (5/8")		PRODUCT CODE	Q'ty / BOX	UNIT WEIGHT	φ(χ)	THICKNESS (PIPE두께)	PIPES	MODEL
 <p>For Bolt Caster 3", 4"</p>	IN-5810L	300	69g	23.6	t1.0	FOR LOGIFORM PIPE	LP-1100	
	IN-5820L		62g	21.6	t2.0		LP-1200	
	IN-5807S		77g	26.4	t0.7	FOR STAINLESS PIPE	ST-1070	
	IN-5811S		72g	25.6	t1.1		ST-1110	

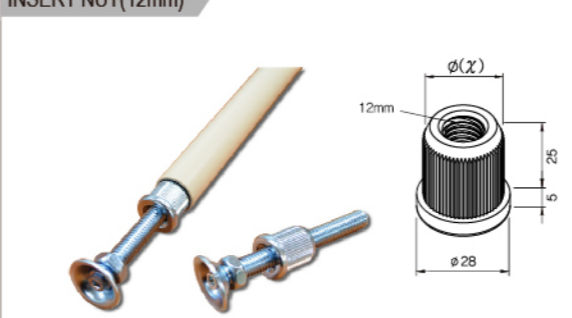
INSERT NUT (10mm)		PRODUCT CODE	Q'ty / BOX	UNIT WEIGHT	φ(χ)	THICKNESS (PIPE두께)	PIPES	MODEL
 <p>For Adjuster</p>	IN-1010LM	300	82g	23.6	t1.0	FOR LOGIFORM PIPE	LP-1100	
	IN-1020LM		70g	21.6	t2.0		LP-1200	
	IN-1007SM		100g	26.4	t0.7	FOR STAINLESS PIPE	ST-1070	
	IN-1011SM		94g	25.6	t1.1		ST-1110	

INSERT NUT(12mm)		PRODUCT CODE	Q'ty / BOX	UNIT WEIGHT	φ(χ)	THICKNESS (PIPE두께)	PIPES	MODEL
 <p>For Adjuster</p>	IN-1210LM	300	72g	23.6	t1.0	FOR LOGIFORM PIPE	LP-1100	
	IN-1220LM		62g	21.6	t2.0		LP-1200	
	IN-1207SM		86g	26.4	t0.7	FOR STAINLESS PIPE	ST-1070	
	IN-1211SM		76g	25.6	t1.1		ST-1110	

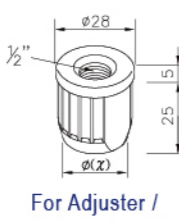
INSERT NUTS - ALUMINIUM

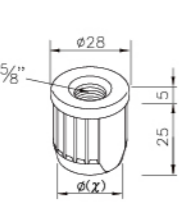
IMAGE	DIMENSION	PRODUCT CODE	Q'ty / BOX	UNIT WEIGHT	φ(χ)	THICKNESS (PIPE두께)	PIPES	MODEL
 <p>For Adjuster / Bolt Caster 2"</p>		IN-1210LA	300	22g	23.6	t1.0	FOR LOGIFORM PIPE	LP-1100
		IN-1220LA		18g	21.6	t2.0		LP-1200
		IN-1207SA		24g	26.4	t0.7	FOR STAINLESS PIPE	ST-1070
		IN-1211SA		22g	25.6	t1.1		ST-1110
 <p>For Bolt Caster 3", 4"</p>		IN-5810LA	300	20g	23.6	t1.0	FOR LOGIFORM PIPE	LP-1100
		IN-5820LA		16g	21.6	t2.0		LP-1200
		IN-5807SA		20g	26.4	t0.7	FOR STAINLESS PIPE	ST-1070
		IN-5811SA		20g	25.6	t1.1		ST-1110

* Please contact HBL's sales representative for an up-to-date product information.

* Please contact HBL's sales representative for an up-to-date product information.